

Technical Specification

*SUPER-NOVA 160÷300 KVA***POWERTRONIX
SUPER-NOVA
160 ÷ 300 KVA**

DT 283-E04

Rev.	Description	Checked
00		14/02/2003 R.Cofani
01	Outline change	24/02/2004 R.Ghezzi
02		09/03/2004 R.Ghezzi
03	Max size 300KVA	10/01/2005 R.Ghezzi
04	Update	08/05/2005 A.Gorlani

Approved:*A.Gorlani***Document:**

DT 283-E04

The UPS of the SUPERNOVA Series are ON-LINE DOUBLE CONVERSION Uninterruptible Power Supply Systems .

The SUPERNOVA series has a special cooling system where the cooling fluid is circulating in a sealed circuit, refrigerated by cooling fans.

All sizes have the same cubicle.

Outline of the SUPERNOVA UPS characteristics are shown here below.



Present document defines technical specs of a new Powertronix high power three phase UPS named S-NOVA covering the power range from 160 to 300 kVA.. These equipments are characterized by reduced size and high efficiency, thanks to the conversion topology, which doesn't need transformers between mains, inverter and load.

S-NOVAUPS belongs to the "double conversion" equipments family, with all advantages given by this topology and without any penalty in total efficiency.

TECHNICAL SPECIFICATION SUPERNOVA

DT283 ED. 04 DATE 08 / 06 / 2005

General features

Double conversion, digital control, trafoless, liquid cooling system

Cubicle arrangement as Powertronix style

Electronic power devices accessible from front, Electronic Control board on Europe

Standard Features

Critical parts accessibility by front of the equipment

Cables inlet from the bottom or from the top

IP 20 protection degree

UPS diagnostic and management on dedicated fiber optic communication

UPS diagnostic and management on teleservice from the factory through SNMPadapter

Modem remote supervision available

Control panel with LCD display, EPO integrated

Remote EPO facility

Connection to a PC available

RS 232 C serial port with DB9 connector

SNMP adapter available

Software development with the most popular operating systems (WINDOWS, NOVELL, UNIX, OS/2)

Additional free contacts for main remote alarms

As proposed for other POWERTRONIX products, suitable options are available to increase behavioural level referred to power management and/or power quality as indicated in the following items:

Harmonics reduction of mains input current

Input / output decoupling with suitable transformer

Mains insulation with suitable insulating transformer

Remote UPS control

TECHNICAL SPECIFICATION SUPERNOVA

DT283 ED. 04 DATE 08 / 06 / 2005

One line diagram

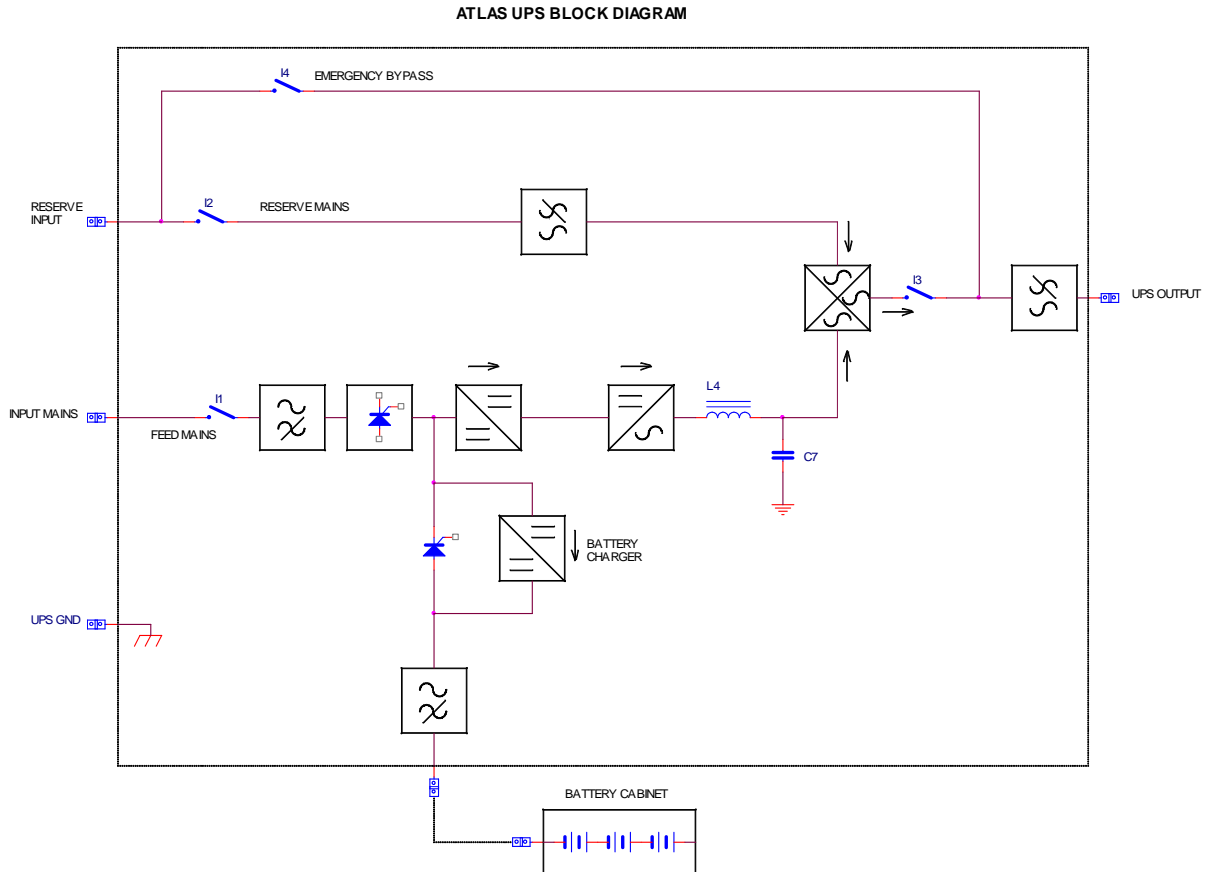

This UPS family is designed according to the following regulations and standards :

CEE 73/23

CEE 89/336

CEI-EN 60950.

CEI-EN 62040-1-1

CEI-EN 50091-2

TECHNICAL SPECIFICATION SUPERNOVA DT283 ED. 04 DATE 08 / 06 / 2005

On-Line Duple Conversion

160-300 kVA

General Features	
Configuration	On-Line Duple Conversion
Input	Total control SCR bridge whit Booster
Inverter	H.F. IGBT technology switching TrafoLess
S.Switch	Electronic SCR S.Switch
Cooling System	Air and Liquid Forced
Reference Norms	IEC-EN62040-1-2 ; IEC-EN62040-1-2 ; IEC-EN62040-1-2 ; IEC 950 Class A UPS
Classification according to norm	VFI-SS-111 nach IEC 62040-3

Mechanical Characteristics	
Lodging	Cabinet
Color	RAL 7035
Mechanical protection degree	IP 20
Advised distances for the positioning	As shown in fig 4 page 20

General dimensions	
UPS dimensions	1800 x 1240 x 800 mm (h x l x p)
UPS dimensions without exchanger	1800 x 1040 x 800 mm (h x l x p)
Ext. Exchanger dimensions	1840 x 300 x 750 mm (h x l x p)

Ambient conditions	
Operatine temperature range	0-40° C (UPS without Batteries) (for the battery see the relative paragraph)
Mean ambient temperature	25° C
Acoustic noise (at 1mt)	65 dB (A)
Relative Humidity	Rel. 10-90% (without condensens)
Maximum installation height without derating	1000 m slm

Display	
LCD-Display	Display LCD 4 lines x 20 characters end 4 functions keys + local EPO
Luminous Alarm	Led status green UPS OK/ Led status red ALARM
Acoustic alarms	Yes

Communication	
RS232	1 board standard and 1 board optional
Free contacts	N° 4 contact: UPS run / UPS in bypass / mains ok / End discharge batteries
SNMP SLOT	Yes
Maintenance software	RS232 Optic
Parallel communication software	RS232 Optic

TECHNICAL SPECIFICATION SUPERNOVA

DT283 ED. 04 DATE 08 / 06 / 2005

Type KVA	160	160 12pulse	160 12pulse + 5%
-----------------	------------	--------------------	-----------------------------

Power			
Power on KVA	160		
Power factor	Cos ϕ 0,8		

Input			
N° of Phase	3		
Nominal voltage	3ph + N	380/400/415 VAC	$\pm 20\%$
Reserve nominal voltage	3ph + N	380/400/415 VAC	$\pm 10\%$
	It is possible without neutral		
Nominal Frequency	50/60 Hz		
Allowable Frequency range	40/70 Hz		
Max current absorbed (A) With battery charger max load ($V_{in} = -20\%$ 400V)	305	305	305
Cos ϕ full load	0,96	0,96	0,96
Power factor			
Input distortion	<30%	<10%	<5%
Soft start	30 sec.		

Output			
N° of phase	3		
Output voltage	3ph + N	380/400/415 VAC	
Max output current (A) (400V nom.)	280		
Voltage static regulation	$\pm 1\%$		
Voltage dynamic regulation (0-100% carico)	$\pm 5\%$		
Recovery time	50 msec.		
Output frequency	50/60 Hz		
Max Synchronizing window	$\pm 1\% / \pm 2\% / \pm 5\% / \pm 10\%$		
Max frequency variation	± 1 Hz per sec		
Output frequency regulation with inner oscillator	$\pm 0,005$ Hz		
Output wave form	Sinus Shape		
THD output linear load	<3%	<3%	<3%
THD output no linear load	CEI - EN 50091-3 allowable		
Crest Factor	CEI-EN 50091-3 allowable		
Efficiency, 100% load	95,4%	93,8%	93,7%
Efficiency, 75% load	95,5%	93,9%	93,8%
Efficiency, 50% load	95,2%	93,6%	93,5%
Efficiency, 25% load	93,5%	91,9%	91,8%
Maximum losses (W) Battery Charger 50A	6355	8355	8555
Power consumption no load (W)	1706	1727	1729
Admitted Overload	125% Pn		

TECHNICAL SPECIFICATION SUPERNOVA DT283 ED. 04 DATE 08 / 06 / 2005

Type KVA	160	160 12pulse	160 12pulse + 5%
-----------------	------------	--------------------	-----------------------------

Battery	
Nominal voltage	480 VDC
Float voltage	540 VDC
Carica fondo	Adjustable
N° of elements	240
Recharge Current	10-50 A DC
Battery test	Yes

Bypass	
Nominal Voltage	3ph + N 380/400/415 VAC
Voltage tolerance	±10%
Frequency	50/60 Hz
Current overload max	10 I _n per 100 ms.
Max time to switching on INVERTER to BYPASS in overload or manual switching to BYPASS on INVERTER and automatic return	< 1ms 0 msec. 0 msec.
Manual By-Pass	Yes

Weights	
UPS weight	570Kg 720Kg 780Kg
Ext. Exchanger	110Kg
Air exchange	800m3h

Optional	
Battery Extension	Yes
Transformer	Isolation trafo in a separate cabinet
Shutdown Software	Powershut Plus Generex PTX
SNMP-Adapter	To connect UPS to the mains
Remote panel	Indicate the status of the UPS at the distance

TECHNICAL SPECIFICATION SUPERNOVA DT283 ED. 04 DATE 08 / 06 / 2005

Type KVA	200	200 12pulse	200 12pulse +5%
-----------------	------------	--------------------	----------------------------

Power			
Power on KVA	200		
Power factor	Cos φ 0,8		

Input			
N° of Phase	3		
Nominal voltage	3ph + N	380/400/415 VAC	±20%
Reserve nominal voltage	3ph + N	380/400/415 VAC	±10%
	It is possibile without neutral		
Nominal Frequency	50/60 Hz		
Allowable Frequency range	40/70 Hz		
Max current absorbed (A) With battery charger max load (Vin = -20% 400V)	369	369	369
Cos φ full load	0.96	0.96	0.96
Power factor			
Input distortion	<30%	<10%	<5%
Soft start	30 sec.		

Output			
N° of phase	3		
Output voltage	3ph + N	380/400/415 VAC	
Max output current (400V nom.)	289		
Voltage static regulation	±1%		
Voltage dynamic regulation (0-100% carico)	±5%		
Recovery time	50 msec.		
Output frequency	50/60 Hz		
Max Synchronizing window	±1% / ±2% / ±5% / ±10%		
Max frequency variation	± 1 Hz per sec		
Output frequency regulation with inner oscillator	± 0,005 Hz		
Output wave form	Sinus Shape		
THD output linear load	<3%	<3%	<3%
THD output nonlinear load	CEI - EN 50091-3 allowable		
Crest Factor	CEI-EN 50091-3 allowable		
Efficiency, 100% load	95,5%	93,9%	93,8%
Efficiency, 75% load	95,7%	94,1%	94%
Efficiency, 50% load	95,6%	94%	93,9%
Efficiency, 25% load	94,3%	92,7%	92,6%
Maximum losses (W) Battery Charger 50A	6200	8200	8400
Power consumption no load (W)	1763	1785	1787
Admitted Overload	125% Pn		

TECHNICAL SPECIFICATION SUPERNOVA DT283 ED. 04 DATE 08 / 06 / 2005

Type KVA	200	200 dodecafase	200 dodecafase 5%
-----------------	------------	-----------------------	------------------------------

Battery	
Nominal voltage	480 VDC
Float voltage	540 VDC
Carica fondo	Adjustable
N° of elements	240
Recharge Current	10-50 A DC
Battery test	Yes

Bypass	
Nominal Voltage	3ph + N 380/400/415 VAC
Voltage tollerance	±10%
Frequency	50/60 Hz
Current overload max	10 I _n per 100 ms.
Max time to switching on INVERTER to BYPASS in overload or manual switching to BYPASS on INVERTER and automatic return	< 1ms 0 msec. 0 msec.
Manual By-Pass	Yes

Weights	
UPS weight	600Kg 780Kg 850Kg
Ext. Exchanger	110Kg
Air exchange	1200m3h

Optional	
Battery Extension	Yes
Transformer	Isolation trafo in a separate cabinet
Shutdown Software	Powershut Plus Generex PTX
SNMP-Adapter	To connect UPS to the mains
Remote panel	Indicate the status of the UPS at the distance

TECHNICAL SPECIFICATION SUPERNOVA DT283 ED. 04 DATE 08 / 06 / 2005

Type KVA	250	250 esafase	250 dodecafase 5%
-----------------	------------	--------------------	------------------------------

Power			
Power on KVA	250		
Power factor	Cos ϕ 0,8		

Input			
N° of Phase	3		
Nominal voltage	3ph + N	380/400/415 VAC	$\pm 20\%$
Reserve nominal voltage	3ph + N	380/400/415 VAC	$\pm 10\%$
	It is possibile without neutral		
Nominal Frequency	50/60 Hz		
Allowable Frequency range	40/70 Hz		
Max current absorbed (A) With battery charger max load (Vin = -20% 400V)	449	449	449
Cos ϕ full load	0,96	0.96	0.96
Power factor			
Input distortion	<30%	<10%	<5%
Soft start	30 sec.		

Output			
N° of phase	3		
Output voltage	3ph + N	380/400/415 VAC	
Max output current (A) (400V nom.)	361		
Voltage static regulation	$\pm 1\%$		
Voltage dynamic regulation (0-100% carico)	$\pm 5\%$		
Recovery time	50 msec.		
Output frequency	50/60 Hz		
Max Synchronizing window	$\pm 1\% / \pm 2\% / \pm 5\% / \pm 10\%$		
Max frequency variation	± 1 Hz per sec		
Output frequency regulation with inner oscillator	$\pm 0,005$ Hz		
Output wave form	Sinus Shape		
THD output linear load	<3%	<3%	<3%
THD output nonlinear load	CEI - EN 50091-3 allowable		
Crest Factor	CEI-EN 50091-3 allowable		
Efficiency, 100% load	95,2%	93,6%	93,5%
Efficiency, 75% load	95,6%	94%	93,9%
Efficiency, 50% load	95,6%	94%	93,9%
Efficiency, 25% load	94,6%	93,2%	92,9%
Maximum losses (W) Battery Charger 50A	6665	8665	8865
Power consumption no load (W)	2001	2026	2029
Admitted Overload	125% Pn		

TECHNICAL SPECIFICATION SUPERNOVA DT283 ED. 04 DATE 08 / 06 / 2005

Type KVA	250	250 dodecafase	250 dodecafase 5%
-----------------	------------	-----------------------	------------------------------

Battery	
Nominal voltage	480 VDC
Float voltage	540 VDC
Carica fondo	Adjustable
N° of elements	240
Recharge Current	10-50 A DC
Battery test	Yes

Bypass	
Nominal Voltage	3ph + N 380/400/415 VAC
Voltage tollerance	±10%
Frequency	50/60 Hz
Current overload max	10 I _n per 100 ms.
Max time to switching on INVERTER to BYPASS in overload or manual switching to BYPASS on INVERTER and automatic return	< 1ms 0 msec. 0 msec.
Manual By-Pass	Yes

Weights	
UPS weight	630Kg 870Kg 990Kg
Ext. Exchanger	110Kg
Air exchange	1200m3h

Optional	
Battery Extension	Yes
Transformer	Isolation trafo in a separate cabinet
Shutdown Software	Powershut Plus Generex PTX
SNMP-Adapter	To connect UPS to the mains
Remote panel	Indicate the status of the UPS at the distance

TECHNICAL SPECIFICATION SUPERNOVA DT283 ED. 04 DATE 08 / 06 / 2005

